

LAB TESTING SUMMARY REPORT

May 2001
Report 030501

Product Category:
Broadband Access Aggregators

Vendor Tested:
Cisco Systems

Product Tested:
Cisco 7200 Series Router



Key findings and conclusions:

- **Successfully terminated 8,000 PPPoA and PPPoE sessions**
- **Passed traffic on all sessions at or near line rate, which was maintained until termination**
- **Supports a compact, 3U footprint and a modular, flexible design with support for over 60 interfaces**

Cisco Systems engaged Miercom to conduct an analysis and performance validation test of its Cisco 7200 Series Router deployed as a Broadband Access Services Aggregator - with emphasis on its ability to terminate PPPoA (point-to-point over ATM) and PPPoE (point-to-point over Ethernet) sessions. We tested the Cisco 7200 Series Router running Cisco IOS version 12.1(5)T1 with an NPE400 processor card and the Broadband Feature License FR-BUS72. Results showed the Cisco 7200 could successfully terminate PPPoA and PPPoE sessions and pass traffic on all sessions at or near line rate (see Performance below for details). All of the tests were conducted at Cisco Systems' labs in Research Triangle Park, NC in April 2001.

Performance Results

The Cisco 7200 Series Router's compact 3U form factor, coupled with its modularity and flexibility and the new broadband User Services License (FR-BUS72) makes it an ideal product for use as a broadband access services aggregator in small- to-medium density aggregation applications in CLECs, ISPs, PTTs and enterprise networks.

Throughput: Percent of Theoretical Maximum*

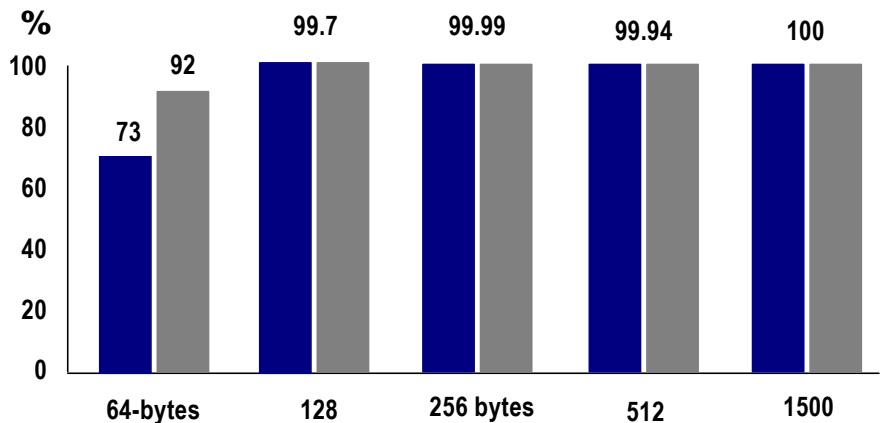

■ = PPPoE Traffic
■ = PPPoA Traffic

Note: Packet size does not include 4-byte checksum.
*Based on Fast Ethernet connections.

Test-bed Setup

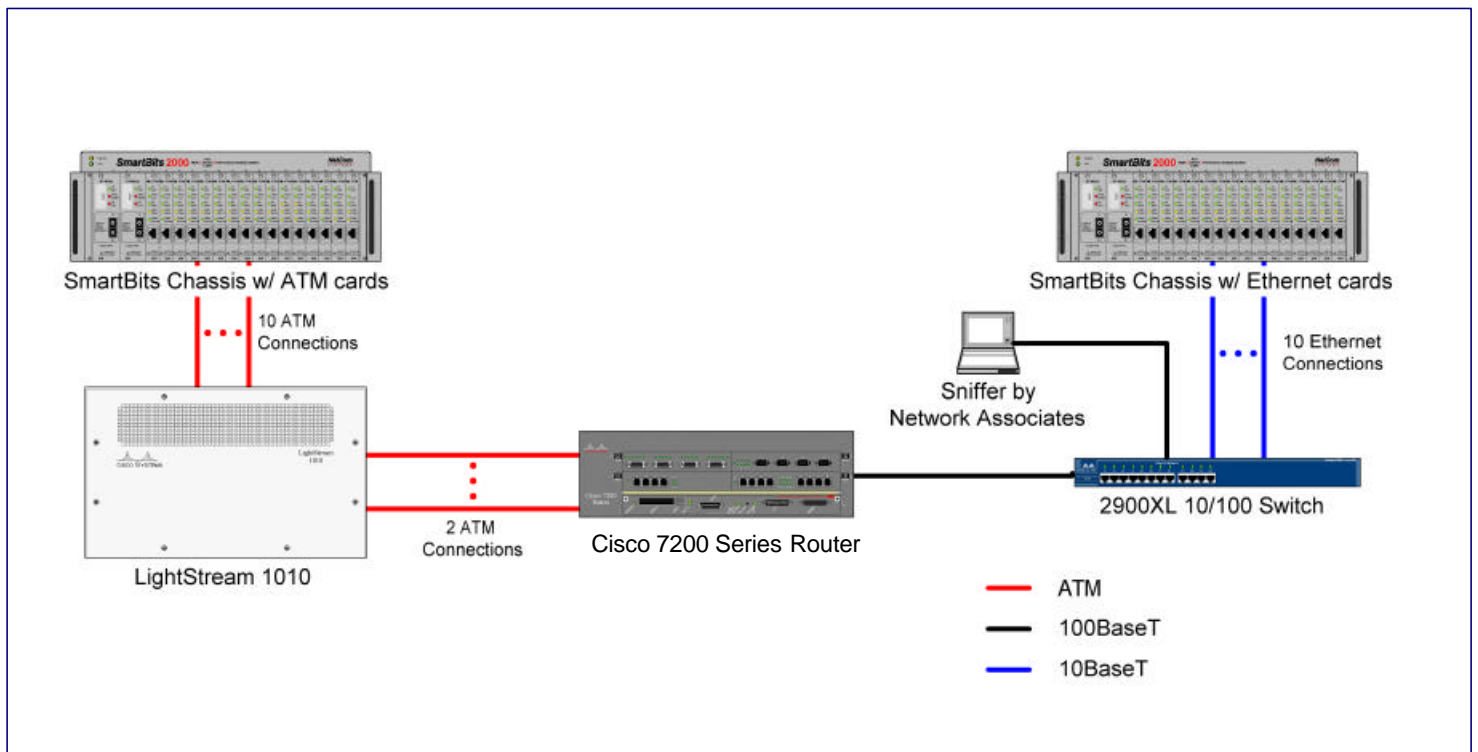

About the testing... We used two Spirent SmartBits chassis firmware with firmware version A0004665. One chassis was equipped with 10 ATM cards with model AT-9155C firmware, version 4.11. The second chassis was equipped with 10 Ethernet cards with model ML-7710 firmware, version 2.20. The Ethernet cards were set to transmit at a 100-percent frame rate for each packet size. The script monitored the throughput and reduced the frame rate, as needed, to achieve less than one-percent frame loss. Frames were transmitted for a total of 20 seconds, starting after all PPPoA or PPPoE connections had been established and verified. PPPoA and PPPoE connections were verified by the SmartBit's script and from the Cisco 7200 Router command line using the statement "show ip local pool." This command reported the number of IP addresses assigned from the DHCP pool (one for each connection established). The script reported back the number of frames transmitted and received on each interface, as well as a total frame loss for the test. The Cisco 2900XL switch was running IOS version 12.0 (5.2) XU. The Lightstream LS1010 ATM switch was running IOS version 11.2(8.0.0)FW4 (1). The Cisco 7200 Series Router under test was running IOS version 12.1(5)T1; it incorporated an NPE400 processor card.

Performance – continued

We were impressed with the product's ability to terminate up to 8,000 sessions and pass traffic on all sessions at or near line rate at various packet sizes. (See Chart on Page 1 and Tables on Page 3 for specifics.)

Throughput results show that, for small packet sizes (64-byte packets), the additional overhead of terminating PPPoA and PPPoE sessions has a negative impact on performance. However, as expected, the performance quickly reaches near

wire speed as packet size increases. Furthermore, it appears that the additional overhead of terminating PPPoE sessions has a greater negative impact on performance than the termination of PPPoA sessions. However, that also recovers to near-wire speed performance, but with slightly larger packet sizes.

We also ran tests to determine the number of PPPoA and PPPoE sessions that can successfully be established and maintained by the Cisco 7200 Series Router. In both instances, the

Performance Results - continued

Cisco 7200 demonstrated that it could establish 8,000 sessions at a rate of 50 sessions per second on the PPPoA connections and at 30 sessions per second on the PPPoE. The Cisco 7200 maintained these sessions throughout the tests and until terminated by the Spirent SmartBits controller or directly from the router's command-line interface.

We also measured latency on PPPoA connections - measured from the initiation of a session (tunnel) to the time the session was established. The average time this took on PPPoA connections was 1,471 msec.

Complete throughput results for both PPPoA and PPPoE sessions are shown below:

Cisco 7200 Series Router: Key Features	
Platform	7204VXR, 7206VXR
Interfaces supported	Over 60 types of WAN interfaces
Operating system	Cisco IOS, version 12.1.1(5)T1
Key services supported	L2TP, PPPoX, VoX, IPsec, MPLS, RFC 1483
Redundancy	Redundant power and HSRP
Management	Cisco Element Framework (CEMF) or CiscoWorks
Price of license for PPPoA and PPPoE	\$2,250
Price (US list) of Cisco 7200 (as tested)	\$37,750 (includes 7206VXR/NPE-400, 2 PA-A3-OC modules and FR-BUS72)

Table 1: PPPoA Throughput Test Results

Packet Size	% Max. Theoretical Transmission Rate	Packets Sent	Packets Received	% Packets Lost	% Max. Theoretical Throughput
64	92	2,640,309	2,627,097	0.50	91.50
128	100	1,661,485	1,656,475	0.30	99.70
256	100	904,123	904,006	0.01	99.99
512	100	468,268	467,968	0.06	99.94
1024	100	240,075	240,075	0.00	100
1280	100	193,030	193,030	0.00	100
1496*	100	165,680	165,680	0.00	100

*The maximum packet size generated by the SmartBits script is 1,500 bytes; however 1,496 bytes were used to allow for additional header information that may be added during PPP sessions.

Table 2: PPPoE Throughput Test Results

Packets Size	% Max. Theoretical Transmission Rate	Packets Sent	Packets Received	% Packets Lost	% Max. Theoretical Throughput
64	73	2,134,715	2,109,022	1.2	71.8
128	100	1,662,227	1,658,255	0.24	99.76
256	100	900,548	900,437	0.01	99.99
512	100	470,535	470,535	0.00	100
1024	100	239,820	239,820	0.00	100
1280	100	193,123	193,123	0.00	100
1490*	100	166,265	166,265	0.00	100

*The maximum packet size generated by the SmartBits script is 1,500 bytes; however, 1,490 bytes were used to allow for additional header information that may be added during PPP sessions.

Conclusions

Performance testing conducted by Miercom demonstrated that the Cisco 7200 Series Router deployed as a Broadband Access Services Aggregator could successfully terminate 8,000 sessions of PPPoA and PPPoE while continuing to pass traffic on all sessions at or near line rate using various packet sizes. Our analysis also showed that sessions could be established at a rate of 50 sessions per second on the PPPoA connections and at 30 sessions per second on the PPPoE. The 7200 maintained these sessions throughout the tests and until terminated.



Cisco 7200 Series Router



Cisco Systems
170 West Tasman Drive
San Jose, CA 95134
Phone: 408-562-4000
Fax: 408-562-4100
www.cisco.com

About Miercom's Product Testing Services...

With hundreds of its product-comparison analyses published over the years in such leading network trade periodicals as *Business Communications Review*, *Network World*, and *Internet Week*, Miercom's (formerly Mier Communications') reputation as the leading, independent product test center is unquestioned. Founded in 1988 by Edwin E. Mier, formerly managing editor of *Data Communications* magazine and a practicing network consultant for over 20 years, the company has pioneered the comparative assessment of networking hardware and software, having developed methodologies for testing products from ATM switches to VoIP gateways and IP PBXs. Miercom's private test services include competitive product analyses, as well as individual product evaluations. Products submitted for review are typically evaluated under the "NetWORKS As Advertised™" program, in which networking-related products must endure a comprehensive, independent assessment of the products' usability and performance. Products that meet the appropriate criteria and performance levels receive the "NetWORKS As Advertised" award and Miercom Labs' testimonial endorsement.

Miercom

410 Hightstown Road, Princeton Junction, NJ 08550
609-490-0200 • fax 609-490-0610 • www.mier.com

Report 030501