

FINE ADJUSTMENTS

NOTE: In order to accurately calibrate your Multimeter, you should perform the following procedures at an ambient temperature of +22°C (+72°F) within $\pm 3^\circ\text{C}$ ($\pm 5^\circ\text{F}$). Two methods of calibration are provided in this part of the Manual. The first method ("Built-in References Method") uses the internal, supplied references. The second method ("Laboratory Standards Method") requires the following laboratory-grade standard references:

1. A DC voltage standard that provides 190 mV DC, 1.9 VDC, and 19 VDC with an accuracy within $\pm .05\%$.
2. An AC voltage standard that provides 1.9 VAC rms with an accuracy within $\pm .1\%$. The output must be a low distortion 100 Hz sine wave.
3. A resistance standard that provides 1.9 k Ω , 19 k Ω , 190 k Ω , 1.9 M Ω , and 19 M Ω with an accuracy within $\pm .025\%$.

Calibration using laboratory standards is somewhat easier than using built-in references, but does not provide any specified improvement in accuracy. Choose one of the calibration methods and perform the steps for that method only. Refer to Figure 1-6 for the steps.

NOTE: If in any of the following steps you do not obtain the indicated results, refer to the "In Case of Difficulty" section. Locate and repair any problem before you continue with the calibration.

BUILT-IN REFERENCES METHOD

Volts DC Calibration

- () 1. Disconnect the connector (on the blue wire) from the CAL pin and route the connector toward the left.
- () 2. Connect the black test lead alligator clip to the connector on the end of the blue wire.

NOTE: If the required display cannot be obtained in step 5 below, alter the condition of LPA (i.e., cut open if closed; solder closed if open) to extend the adjustment range. Then repeat steps 4 and 5.

- () 3. Push the OHMS switch and the 2000k RANGE switch.
- () 4. Touch the black banana plug to the LO CAL test point.
- () 5. Adjust the .2V CAL control (R163) to display the LO CAL number on the calibration label.
- () 6. Push the 20M RANGE switch.
- () 7. Touch the black banana plug to the HI CAL test point.
- () 8. Mentally provide a correction to the HI CAL number on the calibration label by adding 2 to the rightmost digit.
- () 9. Adjust the 2V CAL control (R167) to display the corrected HI CAL number.
- () 10. Repeat steps 3 to 9 until no change in adjustment is required.
- () 11. Disconnect the black test lead and push the connector onto the CAL pin.
- () 12. Push the VOLTS DC switch and the 2 RANGE switch.
- () 13. Plug the red test lead into the IN jack.
- () 14. Touch the red test probe to the HI CAL test point and adjust the V CAL control (R103) to display the HI CAL number.
- () 15. Disconnect the red test lead.

Volts AC Calibration

NOTE: If necessary, refer to "AC CAL Circuit Assembly" on Page 66 and assemble the AC CAL circuit. Then proceed with the following steps.

- () 1. Insert the 1/4" loop ends of the AC CAL circuit into the IN and COM jacks of the Multimeter with the diode side of the circuit positioned at the IN jack.
- () 2. Push the red test lead plug into the lug hole on the diode side of the AC CAL circuit.
- () 3. Push the black test lead plug into the remaining lug hole of the AC CAL circuit.
- () 4. Connect the black test lead alligator clip to a **known** earth ground.
- () 5. Push the VOLTS DC switch and the 200 RANGE switch.

WARNING: When the test probe tip is connected to an AC outlet, hazardous voltages will be present at several places. These are shown by the boxed-in areas in Figure 1-5. Also avoid excessive movement of the AC CAL circuit so you do not short out the line voltage.

- () 6. With **caution**, touch the test probe tip to the line voltage source and observe the display. If no voltage is obtained on one side of the AC outlet, try the other side. Note the voltage display and remove the test probe tip from the line voltage source.
- () 7. Refer to Figure 2-1 (Illustration Booklet, Page 19) and determine the equivalent AC line voltage that corresponds to the voltage you observed in step 6 above.
- () 8. Remove the AC CAL circuit from the Multimeter and connect the test leads directly to the IN and COM jacks.
- () 9. Push the VOLTS AC switch and the 200 RANGE switch (for 120 VAC line voltage) or the 750 RANGE switch (for 240 VAC line voltage).

- () 10. Be sure the black test lead alligator clip is still connected to a **known** earth ground.
- () 11. Carefully touch the test probe tip to the line voltage source and adjust the AC CAL control (R123) for the equivalent AC voltage display determined from Figure 2-1. There may be some variation in the display. Make the adjustment to center any variation around the required display. Allow enough time for the display to stabilize during the adjustment.
- () 12. Repeat steps 5 through 11 until no change in adjustment is required.

Ohms Calibration

- () 1. Connect the black test lead alligator clip to the OHM REF #5 test point. NOTE: If the required display cannot be obtained in step 2 below, alter the condition of LPB (i.e., cut open if closed, solder closed if open) to extend the adjustment range.
- () 2. Push the OHMS switch and the 2k RANGE switch. Touch the test probe to the OHM REF #1 test point. Adjust the 2K CAL control (R156) to display the 2k number on the calibration label.
- () 3. Push the 20k RANGE switch. Touch the test probe to the OHM REF #2 test point. Adjust the 20K CAL control (R143) to display the 20k number on the calibration label.
- () 4. Push the 200k RANGE switch. Touch the test probe to the OHM REF #3 test point. Adjust the 200K CAL control (R145) to display the 200 k number on the calibration label.
- () 5. Push the 2000k RANGE switch. Touch the test probe to the OHM REF #4 test point. Adjust the 2000K CAL control (R147) to display the 2000k number on the calibration label.
- () 6. Repeat steps 2 to 5 until no change in adjustment is required. Then disconnect the alligator clip from the OHM REF #5 test point.

Proceed to "Summary" on Page 90.

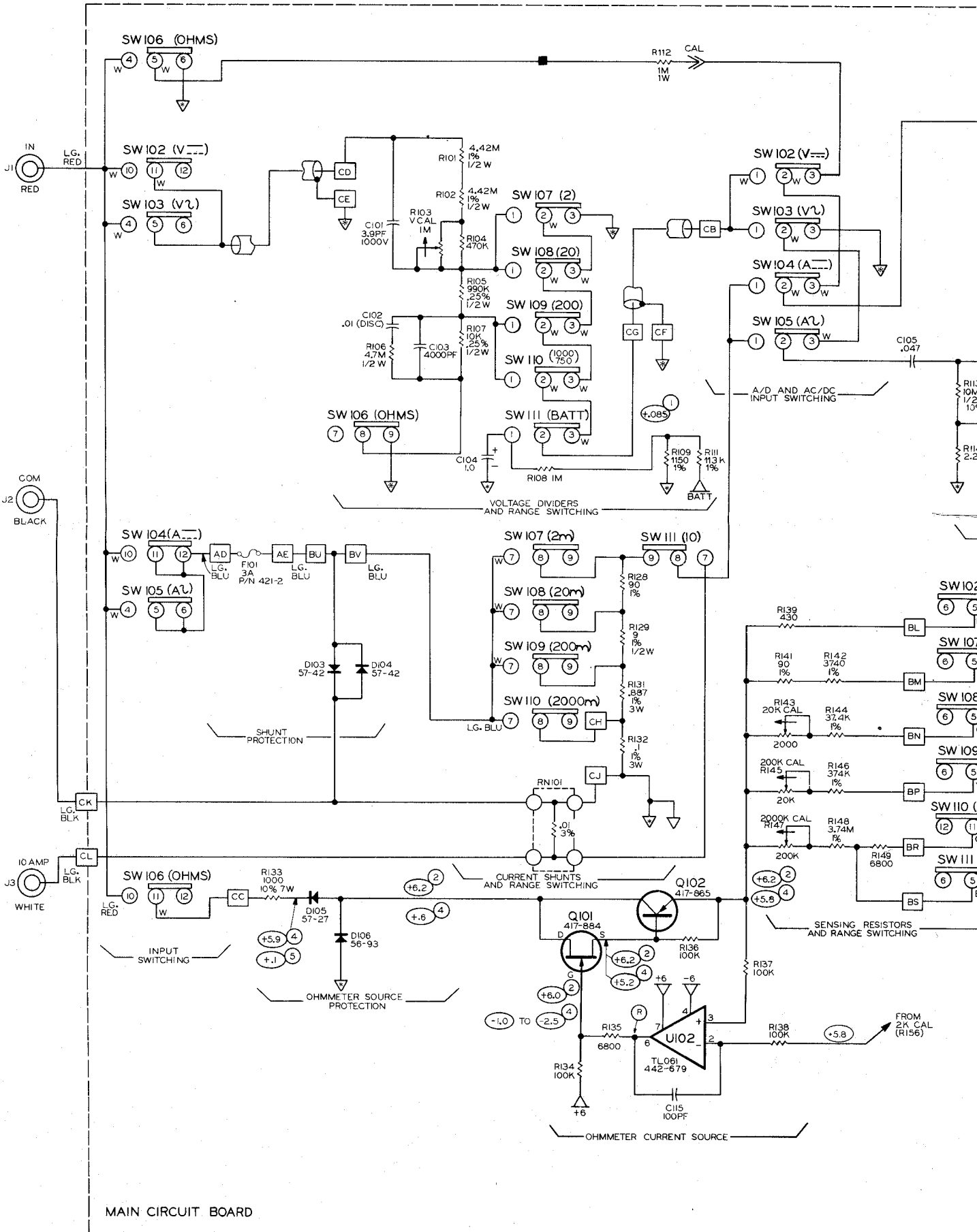

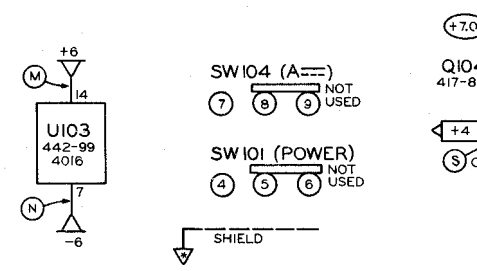
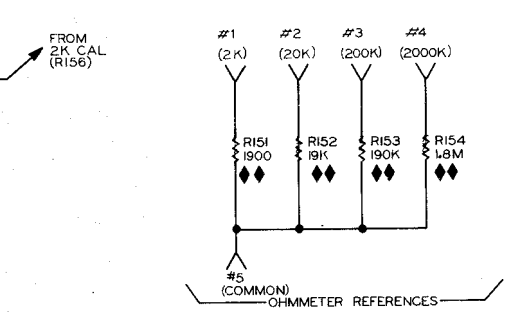
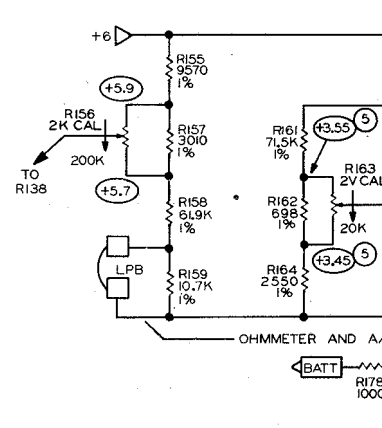
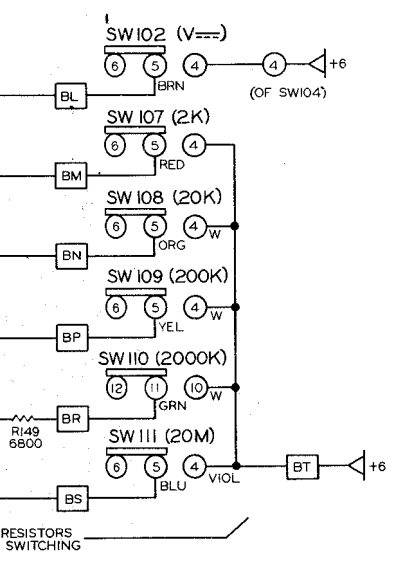
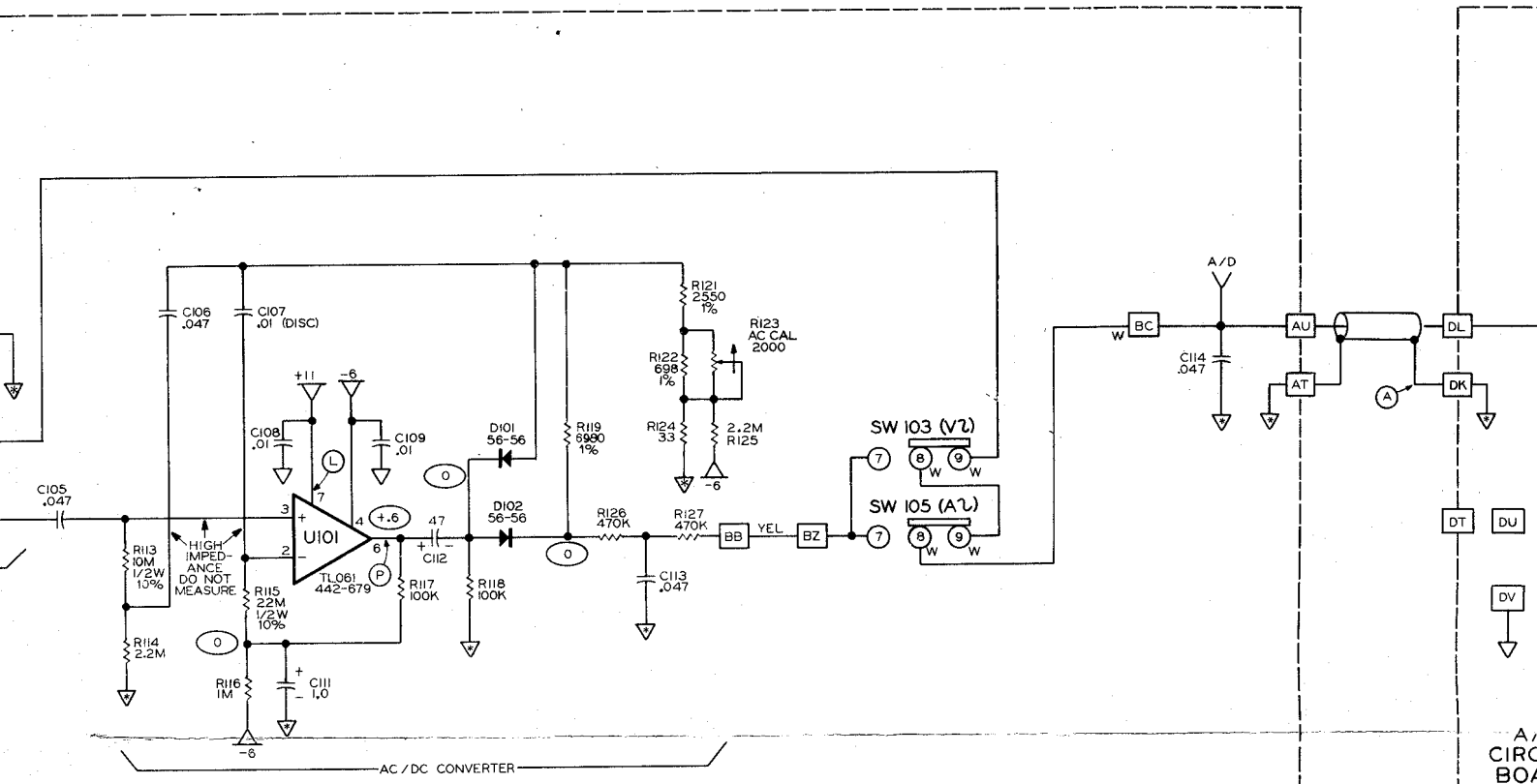

SCHEMATIC OF THE HEATHKIT® DIGITAL MULTIMETER MODEL IM-2260

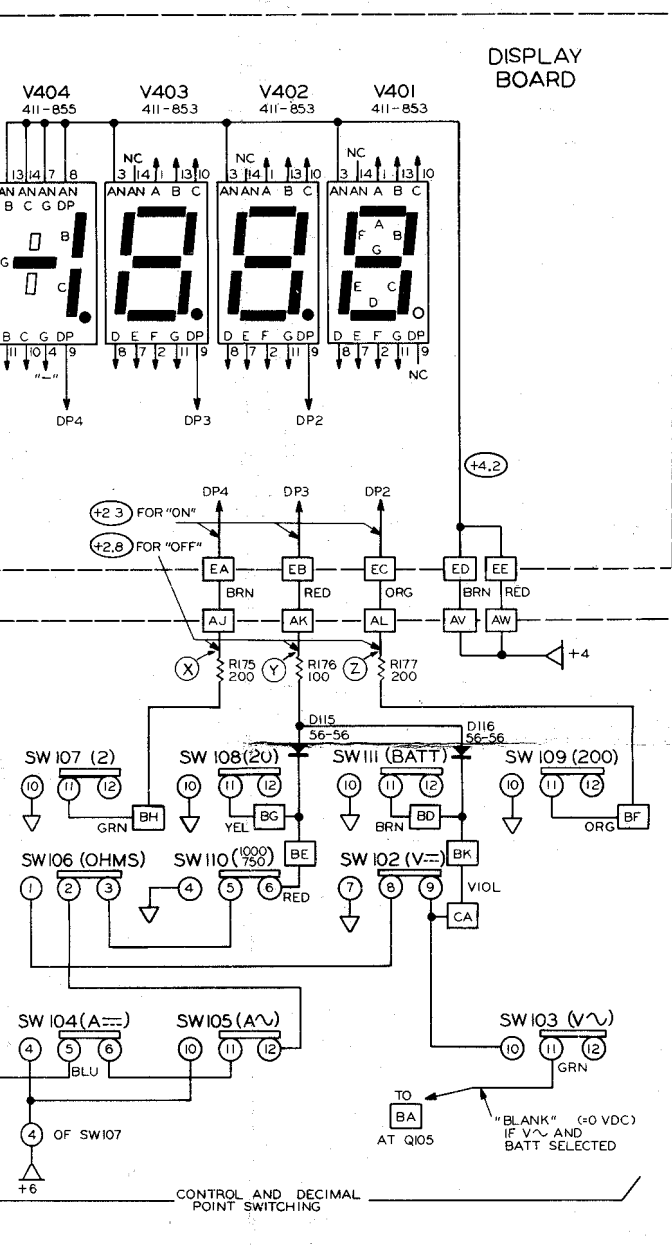

NOTES:

Part of 595-2578

1. REFER TO THE "CIRCUIT BOARD X-RAY VIEWS" FOR THE PHYSICAL LOCATION OF PARTS.
2. REFER TO THE COMPONENT IDENTIFICATION SECTION FOR THE TOLERANCE AND RATING OF COMPONENTS SHOWN ON THE SCHEMATIC.
3. ALL CAPACITOR VALUES ARE IN μF UNLESS OTHERWISE INDICATED.
4. ALL RESISTORS ARE 1/4-WATT, 5% UNLESS OTHERWISE SPECIFIED. ALL RESISTOR VALUES ARE IN OHMS (k=1000, M=1,000,000).
5. ∇ INDICATES POWER GROUND.
6. ∇ INDICATES LOW-NOISE GROUND.
7. \square INDICATES A WIRE CONNECTION TO A CIRCUIT BOARD.
8. \square INDICATES A FOIL-TO-FOIL CONNECTION BETWEEN TWO CIRCUIT BOARDS.
9. Υ INDICATES A TEST POINT OR JUMPER CONNECTION.
10. \bigcirc WITH A NUMBER, INDICATES A SWITCH OR COMPONENT LUG CONNECTION.
11. W INDICATES A BARE OR SLEEVED WIRE.
12. \blacksquare INDICATES A WIRE-TO-WIRE OR TERMINAL STRIP CONNECTION.
13. --- INDICATES A CIRCUIT BOARD FOIL SOLDER PAD.
14. \blacklozenge INDICATES PARTS OF CALIBRATION ASSEMBLY (#100-1806).
15. \blacklozenge INDICATES PARTS OF RESISTOR ASSEMBLY (#100-1735).
16. \bigcirc WITH A LETTER INDICATES A TEST POINT LOCATION FOR "INITIAL TESTS."
17. \hexagon INDICATES A WAVEFORM. REFER TO THE "WAVEFORMS" SECTION OF THE MANUAL.
18. CIRCUIT COMPONENT NUMBERS ARE IN THE FOLLOWING GROUPS:
 - 1-99 PARTS ON THE PANELS OR AC CAL CIRCUIT.
 - 100-299 PARTS ON THE MAIN CIRCUIT BOARD.
 - 300-399 PARTS ON THE A/D CIRCUIT BOARD.
 - 400-499 PARTS ON THE DISPLAY CIRCUIT BOARD.
19. \bigcirc INDICATES VOLTAGE MEASUREMENT IN ANY SETTING OF THE FUNCTION AND RANGE SWITCHES.
20. \bigcirc ¹ INDICATES VOLTAGE MEASUREMENT MAY VARY DEPENDING ON ADAPTOR OR BATTERY VOLTAGE. VALUES ARE GIVEN FOR 8.5VDC.
21. \bigcirc ² INDICATES VOLTAGE MEASUREMENT WITH FUNCTION SWITCH SW102 IN VOLTS DC; RANGE SWITCH SW107 IN 2.
22. \bigcirc ³ INDICATES VOLTAGE MEASUREMENT WITH FUNCTION SWITCH SW102 IN VOLTS DC; RANGE SWITCH SW108 IN 20.
23. \bigcirc ⁴ INDICATES VOLTAGE MEASUREMENT WITH FUNCTION SWITCH SW106 IN OHMS; RANGE SWITCH SW107 IN 2k.
24. \bigcirc ⁵ INDICATES VOLTAGE MEASUREMENT MAY VARY DEPENDING ON V_{COM} (U301, PIN 32). VOLTAGES GIVEN ARE FOR $V_{\text{COM}} = 3.4\text{VDC}$. V_{COM} RANGE = 3.0 TO 3.8 VDC.

NOTE: ALL VOLTAGES WERE MEASURED AT NOMINAL BATTERY VOLTAGE (8.5 VDC) WITH A 10 M Ω (OR HIGHER) INPUT IMPEDANCE DC VOLTMETER. VOLTAGES ARE MEASURED WITH RESPECT TO INPUT COMMON (J2), WITH THE IN (J1) AND COM (J2) JACKS SHORTED. VOLTAGES MAY VARY $\pm 10\%$ EXCEPT AS SHOWN.

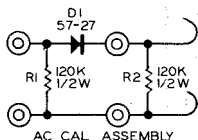

SEMICONDUCTOR IDENTIFICATION CHARTS

DIODES

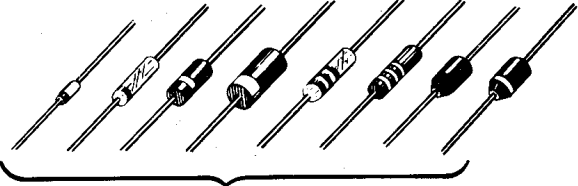
CIRCUIT COMPONENT NUMBER	HEATH PART NUMBER	MAY BE REPLACED WITH	IDENTIFICATION
D114	56-26	1N191	<p>IMPORTANT: THE BANDED END OF DIODES CAN BE MARKED IN A NUMBER OF WAYS.</p>  <p>BANDED END (CATHODE)</p>
D113	Part of #100-1806		
D101, D102, D107, D108, D109, D111, D112; D115 D116	56-56	1N4149	
D106	56-93	FD333	
D1, D105	57-27	1N2071	
D103, D104	57-42	3 A1	

TRANSISTORS

CIRCUIT COMPONENT NUMBER	HEATH PART NUMBER	MAY BE REPLACED WITH	IDENTIFICATION
Q105, Q108	417-801	Selected MPSA20	
Q102, Q103, Q106, Q107	417-865	MPSA55	
Q101	417-884	SF55048	
Q104	417-818	MJE181	

DISPLAYS

CIRCUIT COMPONENT NUMBER	HEATH PART NUMBER	MAY BE REPLACED WITH	IDENTIFICATION
V401, V402, V403	411-853	HP7651	<p>TOP VIEW</p> <p>PIN CONNECTION</p> <ul style="list-style-type: none"> 1. CATHODE a 2. CATHODE f 3. ANODE 3 4. NO PIN 5. NO PIN 6. NO CONN. 7. CATHODE e 8. CATHODE d 9. CATHODE dp 10. CATHODE c 11. CATHODE g 12. NO PIN 13. CATHODE b 14. ANODE 3

Displays (Cont'd.)

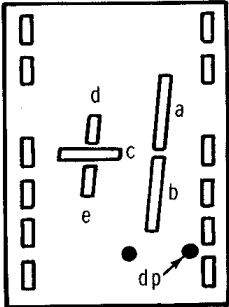
CIRCUIT COMPONENT NUMBER	HEATH PART NUMBER	MAY BE REPLACED WITH	IDENTIFICATION																														
V404	411-855	HP7656	<p style="text-align: center;">TOP VIEW</p>  <table border="1" style="margin-left: auto; margin-right: auto;"> <thead> <tr> <th>PIN</th> <th>CONNECTION</th> </tr> </thead> <tbody> <tr><td>1.</td><td>CATHODE d</td></tr> <tr><td>2.</td><td>ANODE d</td></tr> <tr><td>3.</td><td>NO PIN</td></tr> <tr><td>4.</td><td>CATHODE c</td></tr> <tr><td>5.</td><td>CATHODE e</td></tr> <tr><td>6.</td><td>ANODE e</td></tr> <tr><td>7.</td><td>ANODE c</td></tr> <tr><td>8.</td><td>ANODE dp</td></tr> <tr><td>9.</td><td>CATHODE dp</td></tr> <tr><td>10.</td><td>CATHODE b</td></tr> <tr><td>11.</td><td>CATHODE a</td></tr> <tr><td>12.</td><td>NO PIN</td></tr> <tr><td>13.</td><td>ANODE a</td></tr> <tr><td>14.</td><td>ANODE b</td></tr> </tbody> </table>	PIN	CONNECTION	1.	CATHODE d	2.	ANODE d	3.	NO PIN	4.	CATHODE c	5.	CATHODE e	6.	ANODE e	7.	ANODE c	8.	ANODE dp	9.	CATHODE dp	10.	CATHODE b	11.	CATHODE a	12.	NO PIN	13.	ANODE a	14.	ANODE b
PIN	CONNECTION																																
1.	CATHODE d																																
2.	ANODE d																																
3.	NO PIN																																
4.	CATHODE c																																
5.	CATHODE e																																
6.	ANODE e																																
7.	ANODE c																																
8.	ANODE dp																																
9.	CATHODE dp																																
10.	CATHODE b																																
11.	CATHODE a																																
12.	NO PIN																																
13.	ANODE a																																
14.	ANODE b																																

INTEGRATED CIRCUITS

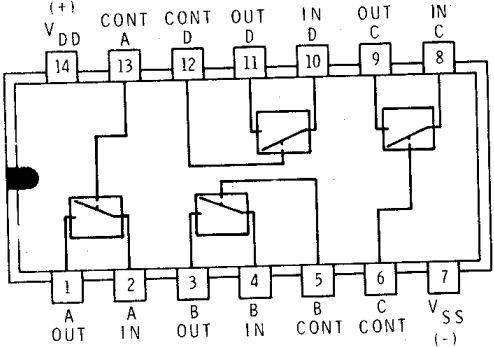
CIRCUIT COMPONENT NUMBER	HEATH PART NUMBER	MAY BE REPLACED WITH	IDENTIFICATION
U103	442-99	CD4016AE	

Integrated Circuits (Cont'd.)

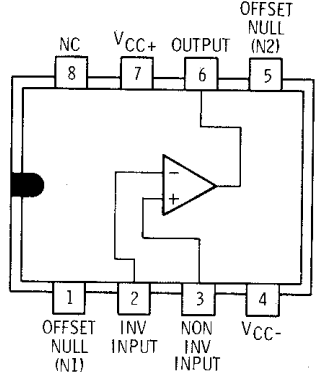
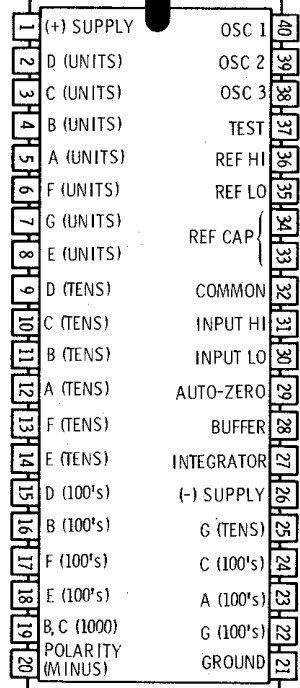
CIRCUIT COMPONENT NUMBER	HEATH PART NUMBER	MAY BE REPLACED WITH	IDENTIFICATION
U101, U102	442-679	TL061CP	
U301	442-724	ICL7107CPL	

CIRCUIT BOARD X-RAY VIEWS

NOTE: To find the PART NUMBER of a component for the purpose of ordering a replacement part:

A. Find the circuit component number (R105, C103, etc.) on the "Circuit Board X-Ray Views."

B. Locate this same number in the "Circuit Component Number" column of the "Parts List."

C. Adjacent to the circuit component number, you will find the PART NUMBER and DESCRIPTION which must be supplied when you order a replacement part.

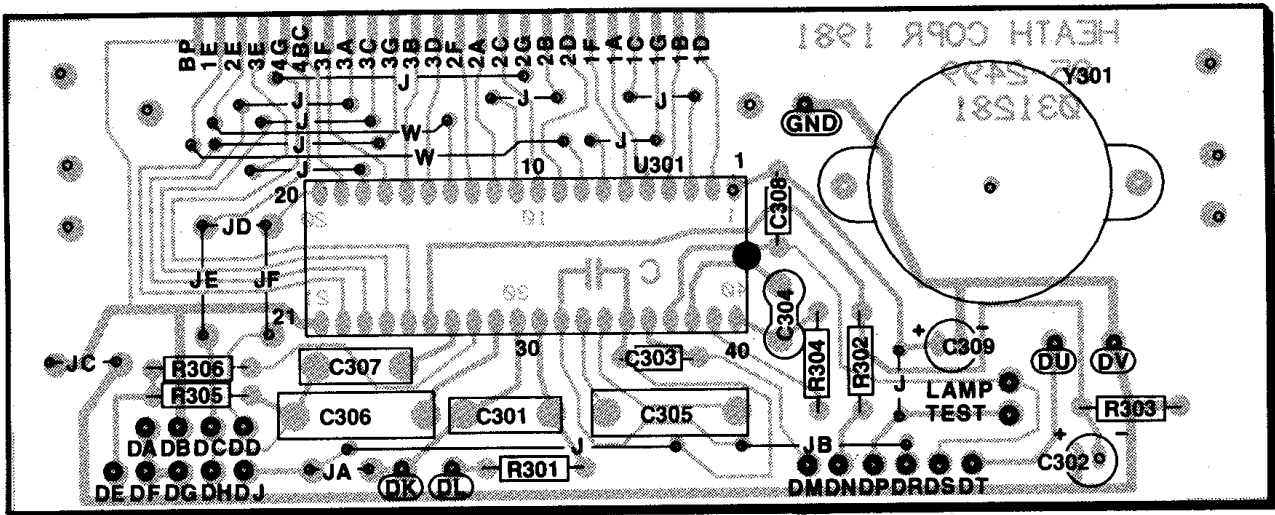

A/D CIRCUIT BOARD
(Viewed from component side)

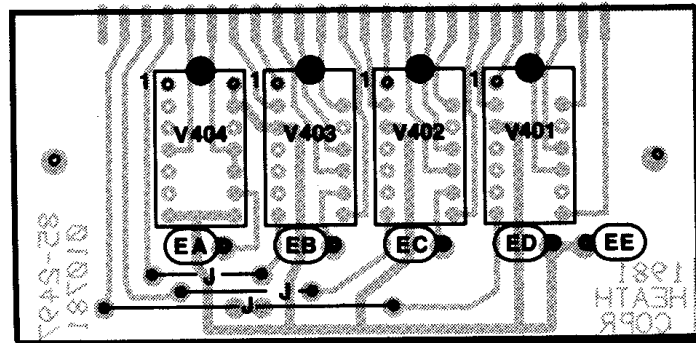

DISPLAY CIRCUIT BOARD
(Viewed from component side)

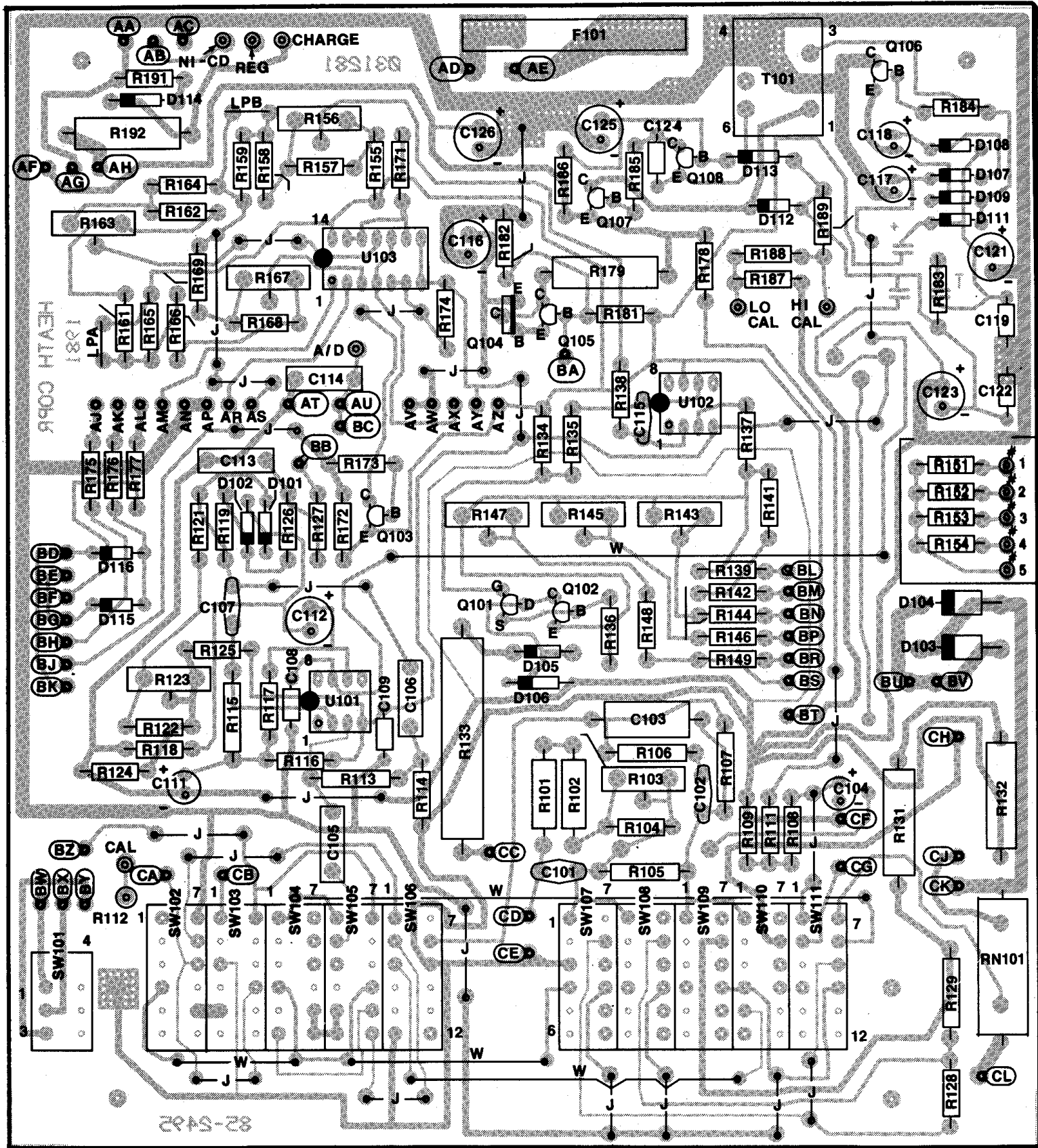

MAIN CIRCUIT BOARD
(Viewed from component side)